



The Industry's Largest Poly IBC Value, Just Got Better!



The world's only plastic intermediate bulk container (IBC) to meet UN/DOT certification standards for packing group II and III materials in a shipping capacity greater than 330 gallons is now available in two different package configurations to meet a wider array of application requirements. The original Megatainer has been modified with an alternative design package for applications not requiring any top lifting capability, which translates into greater cost savings for end users without jeopardizing container performance. The new Megatainer LX delivers all the same safety and performance benefits Snyder IBC users have come to expect from Snyder products and still maintain the industry's highest useful-life-to-cost ratio.

Megatainer, and Megatainer LX, enable bulk packagers and shippers to increase their unit payload capacity to 550 gallons for chemicals that weigh almost 16 lbs. per gallon, which is 66% more capacity than any other poly IBC on the market. Megatainer's unique low profile design makes filling and dispensing quick and easy, while a universal stacking adaptor allows any other IBC design and material construction to be stacked on top of the Megatainer for gravity filling applications.

Whether the application is within a plant or traveling over-the-road, Megatainer, or Megatainer LX, will provide the best material handling value in applications requiring greater container capacity. Call your Snyder IBC representative today to learn more about Megatainer and other revolutionary IBC products.



1-888-IBC-TOTE (422-8683) • FAX: 402-465-1220 • www.snyderibcs.com • email: sales@snydernet.com



Top Lifting Lugs - (optional)
This unique top-lifting component package enables the Megatainer to be easily lift by crane and hoist equipment.

Structural rib design provides unparalleled container strength and durability for all handling applications.

4-way forklift and pallet jack accessibility makes container handling versatile and convenient.

2" replaceable bung opening for accessory installation (draw tube, pressure and/or vacuum relief vents, stacked discharge receiving connections, etc.).

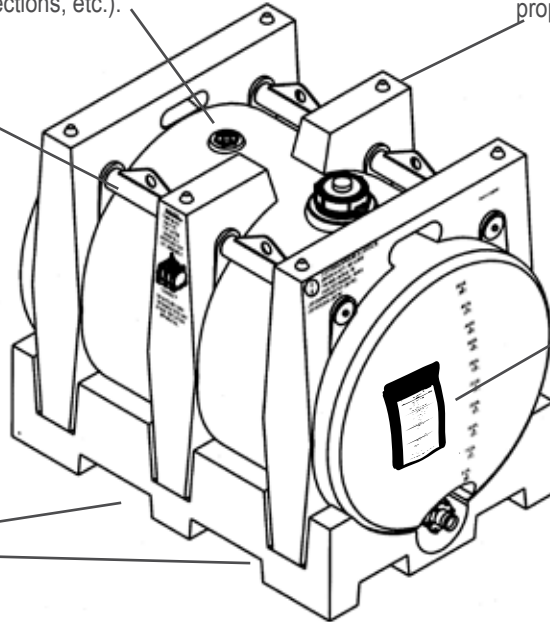

Stacking alignment lug assures containers are stacked securely and that the load is transferred properly.

Unique horizontal design shape creates low profile container with easy access to top ports.

(Option) **MSDS/Placard holder** protects documents from the elements.

UN/D.O.T. certified (UN 31H2) for Packing Group II and III per Title 49 CFR.



Trailer Mount attachments (optional) Megatainer and other Snyder IBCs can be mounted to a trailer with non-regulated or exempt applications and be directly discharged from a motor vehicle without having to move the container itself.

Megatainer				
Capacity	Tare Weight	Length	Width	Height
550 Gallons	570 lbs.	81"	48"	60"
550 Gallons	542 lbs.	81"	48"	60"

Material weight rating - 1.9 specific gravity. Test pressure: 14.7 psig.
Stacking capacity 2-3 units high depending on material weight and temperature exposure.

✓ **Save Space with Megatainer!**

✓ **Less Labor Filling, Handling, and Dispensing!**



1 Megatainer



2 Limited Use IBCs



10 Drums



SOLUTIONS IN BULK HANDLING

6940 "O" Street, Suite 100 • Lincoln, Nebraska 68510 • 1-888-IBC-TOTE(422-8683) • FAX: 402-465-1220 • www.snyderibcs.com • email: sales@snydernet.com
Other manufacturing facilities: Marked Tree, Arkansas • Chowchilla, California • Philippi, West Virginia • Mancelona, Michigan
West Chicago, Illinois • Bensenville, Illinois