

Snyder Industries Inc.

Stand Mounted Mixer Bracket Assembly Instructions for P/N 3471238

Contents of package:

Item	Quantity	Part Number
3/8 x 6 1/2 in. hex head bolt	4	350119
3/8 x 2 1/2 in. hex head bolt	6	350120
3/8 x 4 in. hex head bolt	2	350121
3/8 flat washer	12	351011
3/8 nylon locking hex nut	12	351141
Vertical support tube	2	359616
Horizontal support tube	1	359617
Leg mount bracket	2	359618
Mixer mounting plate	1	359619
Bag 8 x 12 w/draw string	1	995004
Assembly instructions	1	998066

1. Clamp leg mount brackets (A) to stand legs (B) with the brackets centered over the base of the stand. Using a straightedge (C) along the face of the brackets, check to see the brackets are properly aligned and square with one another. If they're not square, adjust the brackets accordingly (see fig. 1).
2. Once the brackets are set in place, use a 7/16 in. drill bit to drill 2 holes into each side of both the stand legs using the holes in the leg mount brackets as guides (see fig. 1). Note: do NOT drill straight through the legs from one side only, as this could lead to the holes in the legs not lining up properly.

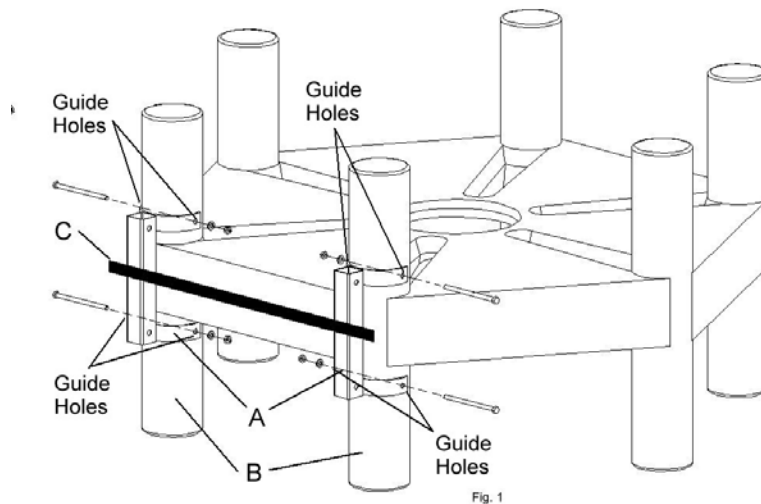

3. Use the supplied 6 1/2 in long bolts to secure the leg mount brackets to the stand legs by sliding 1 bolt through each of the 4 sets of drilled holes in the stand legs. Place a washer and nut on each of the bolts and tighten until snug (see fig. 1).
4. Insert 1 vertical support tube (D) into each of the leg mount bracket slots and attach using 4 of the 2 1/2 in long bolts. Place a washer and nut on each of the bolts and tighten until snug (see fig. 2).

Snyder Industries Inc.
Stand Mounted Mixer Bracket Assembly Instructions for P/N 3471238

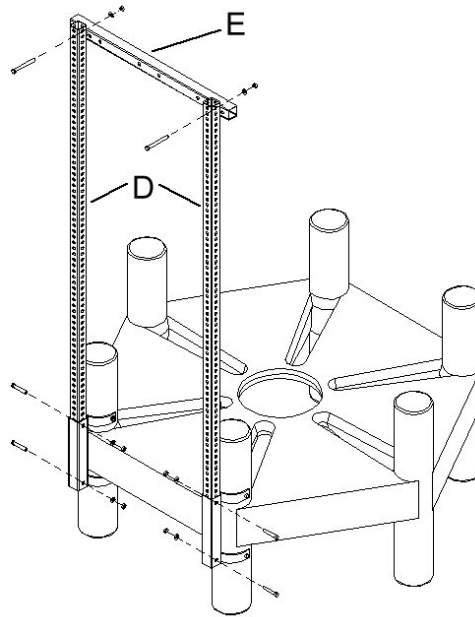

Fig. 2

5. Using the 4 in long bolts, attach the horizontal support tube (E) to the vertical support tubes at the desired height. Remember to make sure the horizontal support tube is placed where it will be just above the top lip of the tank (see fig. 2). Place a washer and nut on each of the bolts and tighten until snug.
6. Attach the mixer mounting plate (F) to the center of the horizontal support tube (E) using the remaining two 2 1/2 in long bolts. Place a washer and nut on each of the bolts and tighten until snug (see fig. 3).

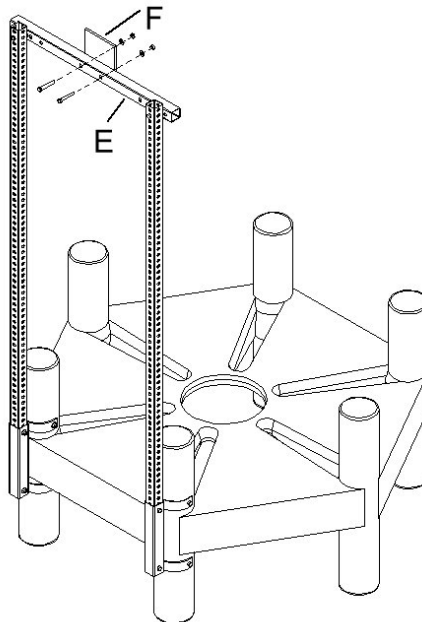

Fig. 3

Note: This mixer bracket assembly is fully adjustable, so if you need it to function with different sized open top tanks, simply remove the bolts holding the horizontal support tube with mounting plate and set it to the desired height.